



Building Automation

Industrial Automation

Systems

Hardware and Engineering

Overload Relay EMT6 Overload monitoring system for machines operating in the EEx e area

07/03 AWB2327-1446GB

MOELLER 

Think future. Switch to green.

For Moeller Electric Sales and Support call KMparts.com (866) 595-9616

All brand and product names are trademarks or registered trademarks of the owner concerned.

1st published 2002, edition date 02/02

2nd edition 07/2003

See revision protocol in the "About this manual" chapter

© Moeller GmbH, 53105 Bonn

Author: Wolfgang Nitschky

Editor: Heidrun Riege

Translator: David Long

All rights reserved, including those of the translation.

No part of this manual may be reproduced in any form (printed, photocopy, microfilm or any other process) or processed, duplicated or distributed by means of electronic systems without written permission of Moeller GmbH, Bonn.

Subject to alteration without notice.

Printed on bleached cellulose.

100 % free from chlorine and acid.



Warning! Dangerous electrical voltage!

Before commencing the installation

- Disconnect the power supply of the device.
- Ensure relosing interlock that devices cannot be accidentally restarted.
- Verify isolation from the supply.
- Connect to earth and short-circuit.
- Cover or fence off neighbouring live parts.
- Follow the installation instructions (AWA) included with the device.
- Only suitably qualified personnel in accordance with EN 50110-1/-2 (VDE 0105 Part 100) may work on this device/system.
- Before installation and before touching the device ensure that you are free of electrostatic charge.
- The rated value of the mains voltage may not fluctuate or deviate by more than the tolerance specified, otherwise malfunction and hazardous states are to be expected.
- Panel-mount devices may only be operated when properly installed in the cubicle or control cabinet.

Contents

<hr/>	
	About this manual 3
	Target group 3
	Abbreviations and symbols 3
	Modification index 4
<hr/>	
1	EMT6 thermistor machine protection relay 5
	Preface 5
	System overview 6
	Unit description 6
	– Direct temperature monitoring using thermistors 6
	– Thermistor protection 7
	– Device variants 8
	– Reset after triggering 10
	– Zero-voltage protection 10
	– Short-circuit monitoring of the thermistor circuit 11
<hr/>	
2	Configuration 13
	Monitoring overload of motors in the EEx e area 13
	Approvals 14
<hr/>	
3	Installation 15
	Notes on installation 15
	Mounting the devices 17
	– Terminals 18
	– Conductor cross-sections 19
	Control voltage 19
<hr/>	
4	Operating the devices 21
	Automatic reset 21
	Manual reset 22
	Reclosing interlock and short-circuit protection 23
	Test/Reset 24
	Device fault 24

Annex	25
Rating plates	25
Dimensions	27

About this manual

This manual applies for the EMT6 thermistor overload relay. It describes the overload monitoring system for the protection of motors operating in potentially explosive atmospheres (EEx e areas).

Target group

This manual addresses qualified personnel who install, commission and maintain the thermistor overload relay.

Abbreviations and symbols

The abbreviations and symbols used in this manual have the following meaning:

EEx e	"Increased safety" type of protection
TNF	Rated threshold temperature
PTB	Physikalisch Technische Bundesanstalt (German Federal Testing Laboratory), accredited certification authority for devices operated in EEx e areas.
PTC	Positive temperature coefficient thermistor, temperature detector with positive temperature coefficient

► Indicates actions to be taken.



Draws your attention to interesting tips and supplementary information.



Note

Indicates the possibility of minor material damage.



Warning!

Indicates the possibility of major material damage and major injuries or death.

For greater clarity, the name of the current chapter is shown in the header of the left-hand page and the name of the current section is shown in the header of the right-hand page. Exceptions are the first page of a chapter and empty pages at the end of a chapter.

Modification index

Edition date	Page	Subject	New	Change	Deleted
07/03	8, 10, 18, 19,	Device types augmented		✓	
	11	Section "Short-circuit monitoring of the thermistor circuit"		✓	
	14	Section "Approvals"		✓	
	21	Section "Automatic reset"		✓	
	22	Section "Manual reset"		✓	
	25	Section "Rating plates"		✓	

1 EMT6 thermistor machine protection relay

Preface

In addition to the type of protection specified for motors in potentially explosive atmospheres and areas as specified in the EN 60079-14 and VDE 0165 Part 1 (German standard) standards, further provisions also apply for the respective types of protection. EN 50019 demands additional measures for operating motors with "increased safety" type of protection "e". These measures provide an enhanced degree of safety for protection against impermissible high temperatures and against the development of sparking and arcing on the motors, which does not usually occur under normal operating conditions. The motor protective devices used for this are operated outside of the EEx e area and must be certified by an accredited certification authority.

The guidelines on the application of Directive 94/9/EC (ATEX 100a) on the approximation of the laws of the Member States concerning equipment and protective systems intended for use in potentially explosive atmospheres will be enforced as of 30 June 2003.

The thermistor overload relay EMT6 is approved by the PTB according the 94/9/EC (ATEX 100a) Directives.



Number of the EU certificate of compliance:
PTB 02 ATEX 3162.

System overview



Figure 1 : Overload protection relays EMT6, EMT6-DB and EMT6-DBK

Unit description

To protect the machinery from overload, direct temperature monitoring systems can be used in addition to current-dependent protective devices. The EMT6 overload relays monitor the thermistor sensors used for monitoring temperature and switch off the power relay in the event of overheat in the machinery.

Direct temperature monitoring using thermistors

The motor current can also be used to monitor motor overtemperature in addition to the indirect method of temperature monitoring. For this, the motor manufacturer implements integral thermistors in the motor windings. Apart from the sole purpose of motor protection, thermistors are also used to monitor the temperature of motor and machine bearings. They are also commonly used for

temperature monitoring of heating systems, heating circulation fans, in the windings of various sizes of transformers, for generator protection as well as for monitoring gaseous or liquid coolants, and temperature monitoring of non-electrical mechanical equipment.

Thermistors are step-action temperature sensors, also referred to as PTC resistors or positive temperature coefficient resistors. Their resistance changes sharply when a defined temperature is exceeded.

The thermistors are monitored by the thermistor overload protection relay EMT6.

Thermistor protection

For the protection against overtemperature, up to six PTC resistor temperature sensors to DIN 44081 PTC Resistors, or up to two temperature sensors to DIN 44082 Triple PTC Resistors with a PTC resistance of $R_K \leq 250 \Omega$, or nine sensors with a PTC resistance of $R_K \leq 100 \Omega$ can be connected to the EMT6 terminals T1-T2 (→ Fig. 7, Page 18).

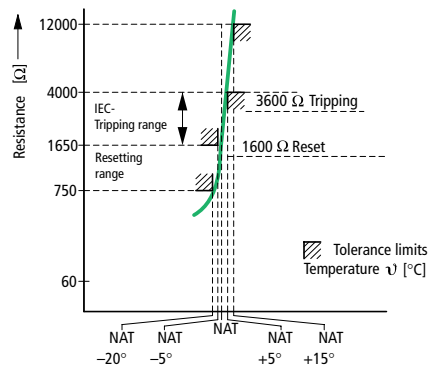

Figure 2 : Characteristic curve for monitoring temperature with a thermistor

The EMT6 switches off at $R = 3600 \Omega \pm 10 \%$ and switches on again at $R = 1600 \Omega \pm 10 \%$. The contacts 13-14 and

21-22 change over in the event of a shutdown caused by a signal at the thermistor input (↔ Fig. 4, Page 16).



Hazardous states are also excluded in case of sensor failure when temperature is monitored with thermistors, since the unit is here switched off instantaneously.



Warning!

Response of the thermistor monitoring unit must also result in a direct shutdown when the motor is controlled by means of an inverter. This must be ensured by circuit design.



Warning!

A separate overload protection system must be installed for the electrical equipment.

Device variants

The EMT6 thermistor overload protection relay is available in seven variants:

- EMT6 and EMT6(230V)
- EMT6-K
- EMT6-DB and EMT6-DB(230V)
- EMT6-KDB
- EMT6-DBK

These units differ in their functions.

The following table indicates the differing features of the five device-related variants:

	EMT6 EMT6(230V)	EMT6-K	EMT6-DB EMT6- DB(230V)	EMT6-KDB	EMT6-DBK
Function					
Automatic Reset	+	+	+	+	+
Manual Reset	-	-	+	+	+
Detection of short-circuit in the sensor circuit	-	+	-	+	+
Zero-voltage safety	-	-	-	-	+
Operator control					
Test button	-	-	+	+	+
Reset button	-	-	+	+	+
Remote reset	-	-	+	+	+
Selector switch MANUAL/AUTO reset	-	-	+	+	+
Display					
Operating voltage	+	+	+	+	+
Tripping	+	+	+	+	+
Fault short-circuit	-	+	-	+	+
Voltage					
Multiple voltage of 24 V to 240 V ~/---	+	+	+	+	+
Single voltage 230 V ~	+	-	+	-	-

Reset after triggering

The error message of the standard EMT6 is automatically reset after the equipment (motor winding) temperature has dropped to a sufficiently low level. The operating mode of the EMT6-DB, EMT6-KDB and EMT6-DBK variants can be set to "Automatic" or "Manual reset" using the selector switch. In automatic mode, the devices are reset automatically as described above. In manual mode, they are reset after the motor has cooled down.

The EMT6-DB, EMT6-KDB and EMT6-DBK have an additional option of connecting a button as a remote reset for manual mode.



Warning!

To ensure explosion-proof operation, it is permitted only to reset/switch on the motor manually after it has cooled down, or to switch it on automatically via a control interlock circuit for the motor or electrical machinery.

A manual reset may be carried out on-site or from the control room by trained personnel.

Zero-voltage protection

Zero-voltage protection means that the error message is retained even after loss of the supply voltage. Zero-voltage protection can be enabled or disabled on the EMT6-DBK. If the equipment has not yet cooled down sufficiently after power is returned, the relays with disabled zero-voltage protection will also be tripped again. The message of devices with disabled zero-voltage protection will be lost only if power is returned after the equipment has cooled down during an extended period of power loss.

**Warning!**

Particularly in EEx e applications, an automatic restart must be prevented after an interruption of the control voltage. This is prevented safely by means of the latching mechanism of the power relay (→ Fig. 4, Page 16).



Zero-voltage safety can be disabled at the EMT6-DBK by means of a wire jumper between terminals Y1-Y4.

Short-circuit monitoring of the thermistor circuit

The sensor circuits of all EMT6 units are equipped with a wire-break (open-circuit) safety sensor circuit. The sensor circuits of the EMT6-K, EMT6-KDB and EMT6-DBK have additional short-circuit monitoring in the sensor circuit which immediately switches off the relay when the resistive load of the sensor circuit drops below a minimum value.



The short-circuit monitoring of the EMT6-DBK can be disabled by means of a wire jumper between terminals Y1-Y3 (→ Fig. 7, Page 18).

**Warning!**

Short-circuit monitoring is essential in the sensor circuit to monitor EEx e motors. Monitoring of short-circuits may not be disabled.

When using the EMT6 or EMT6-DB, a current monitor (→ Fig. 3, Page 12) must be used in the thermistor circuit to monitor short-circuits.

**Caution!**

The maximum short-circuit current of the thermistor input is 1.9 mA.

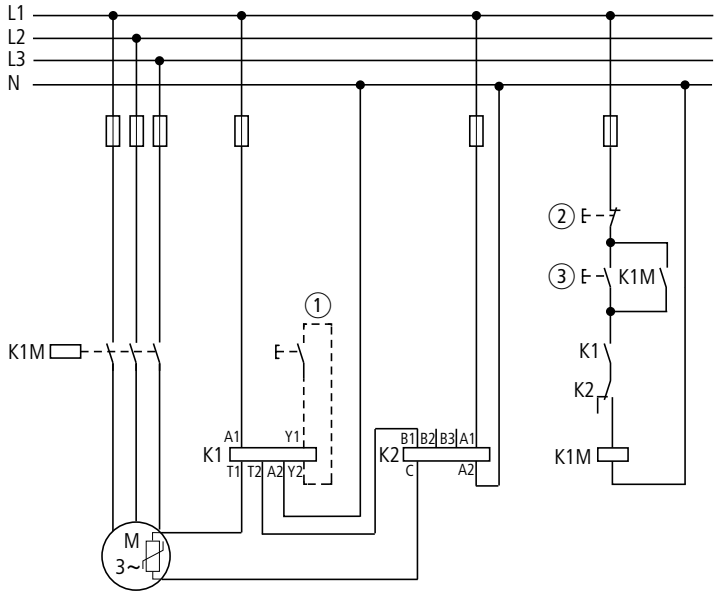

Figure 3 : Short-circuit monitoring of the thermistor circuit using a current monitor

- ① Remote reset
- ② STOP
- ③ START

2 Configuration

Monitoring overload of motors in the EEx e area

The “EEx e” type of protection for motors is achieved by means of special constructive measures. The motors are assigned to temperature classes based on the maximum permitted surface temperatures. The heating time t_E and the ratio between startup current and rated current I_A/I_N are additionally calculated and specified on the motor.

The safe locked-rotor time t_E represents the time it takes for the rotor winding to heat up from its final rated operational temperature up to the limit temperature at a starting current of I_A .

However, EEx e motors are not intrinsically safe. Explosion safety is only achieved by selecting further appropriate installation measures and operating conditions (PTB testing regulations), e.g. by combination of the circuit with a correctly rated and set temperature monitoring system.

The machine manufacturer equips the machine at its critical temperature points with integral thermistors to DIN 44081, which are selected according to the appropriate rated threshold temperature. They develop a high resistance after their rated response temperature is exceeded. The thermistors must be compliant with the following limits according to standards:

- $\vartheta_{NAT} -5 \text{ K}: R \leq 550 \Omega$
- $\vartheta_{NAT} +5 \text{ K}: R \geq 1330 \Omega$
- $\vartheta_{NAT} +15 \text{ K}: R \leq 4000 \Omega$

The thermistor overload relay monitors the thermistors and switches an auxiliary circuit when the critical temperature is exceeded.

Approvals

The EMT6 overload relay has been manufactured in compliance with the IEC/EC 60947 low-voltage switchgear and DIN VDE 0660-303A regulations, and fulfils the 94/9/EC (ATEX 100a) guideline for protection of EEx e motors. Furthermore, motors can be explosion protected in zones 21 and 22 (areas with combustible dusts) in compliance with EN 50281-1-1 and EN 50281-1-2.

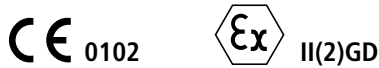

The EMT6, EMT6-DB and EMT6-DBK relays are approved by the UL and CSA for the USA and Canada.

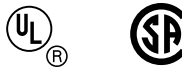

Further approvals exist for

- Romania **ML PAT**
- Russia 

3 Installation

Notes on installation

The notes in the current AWA2327-1454 installation manual which accompany the devices must be observed during mechanical and electrical installation of the devices.



Warning!

To ensure explosion-proof operation, it is permitted only to reset/switch on the motor manually after the thermistor has cooled down, or to switch it on automatically via a control interlock circuit for the motor or electrical machinery.

A manual reset may be carried out on-site or from the control room by trained personnel.



Warning!

Particularly in EEx e applications, an automatic restart must be prevented after an interruption of the control voltage. This is prevented safely by means of the latching mechanism of the power relay.

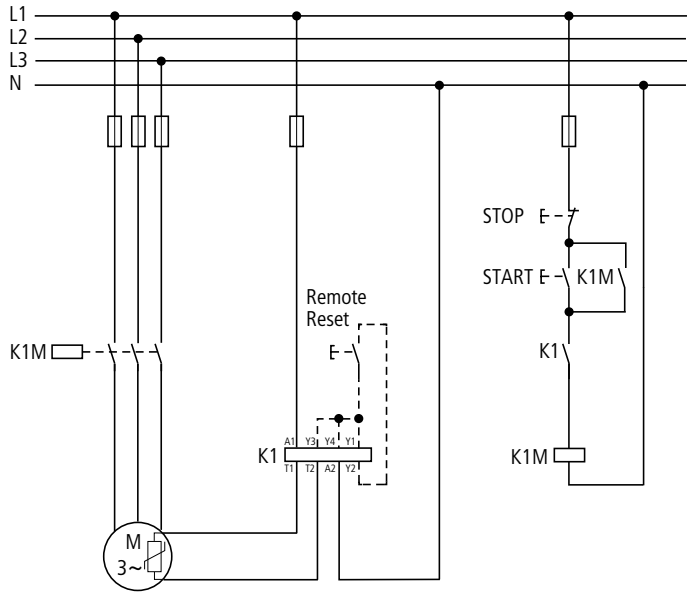

Figure 4 : The circuit prevents an automatic restart.

The latching mechanism of the K1M contactor relay prevents an automatic restart.

Mounting the devices

The EMT6... can be mounted in any required position.

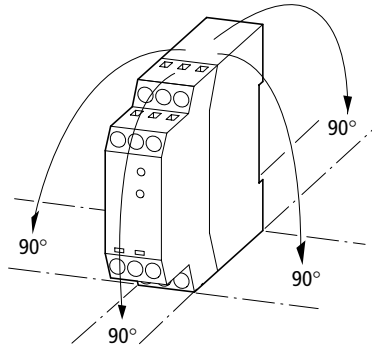

Figure 5 : Mounting position EMT6

The device can be optionally mounted on DIN-rail or screw-mounted by using a CS-TE adapter.

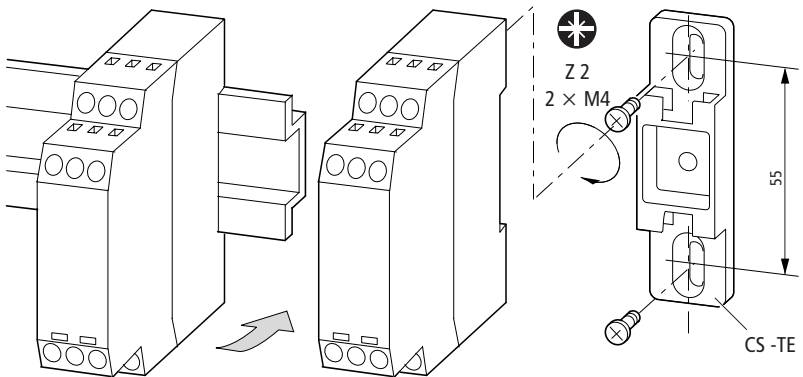

Figure 6 : Mounting of the EMT6

Terminals

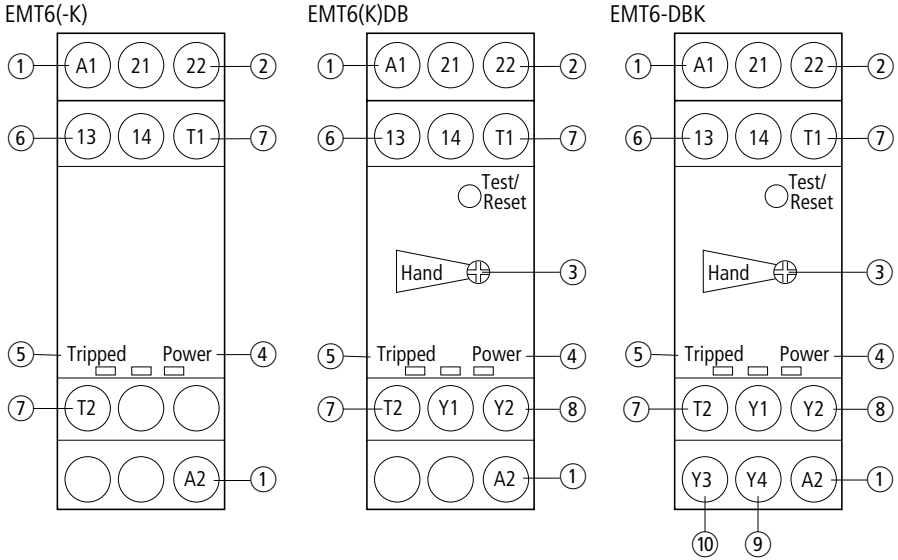

Figure 7 : Terminals





- ① A1-A2 Rated control voltage supply
- ② 21-22 Auxiliary normally closed contact
- ③ Manual/automatic reset
- ④ Mains LED (green)
- ⑤ Tripped LED (red)
- ⑥ 13-14 Auxiliary normally open contact
- ⑦ T1-T2 Thermistor
- ⑧ Y1-Y2 Remote reset
- ⑨ Y1-Y4 Zero-voltage safety disabled
- ⑩ Y1-Y3 Short-circuit monitoring disabled

The one-way length of the sensor cable connected to T1-T2 and the remote reset cable connected to Y1-Y2 may not exceed 250 m.

Short-circuit monitoring in the sensor circuit can be disabled by bridging the terminals Y1-Y3. A jumper between the terminals Y1-Y4 disables zero-voltage protection.

Conductor cross-sections

Table 1: T Conductor cross-sections of the auxiliary cables

 mm²	 mm²	AWG	 mm		Nm
1 × (0.5 to 2.5)	1 × (0.5 to 2.5)	20 to 14	0.8 × 4 0.8 × 5.5	Z2	0.8 to 1.2
2 × (0.5 to 1.5)	2 × (0.5 to 1.5)	20 to 14	0.8 × 4 0.8 × 5.5	Z2	0.8 to 1.2

Control voltage

EMT6... units can be operated with the following control voltages:

Table 2: T Control voltages and voltage safety

	EMT6 EMT6-K EMT6-DB EMT6-KDB EMT6-DBK	EMT6(230V) EMT6-DB(230V)
AC control voltage	24 V to 240 V 50/60 Hz	230 V 50/60 Hz
DC control voltage	24 V to 240 V ---	—
AC voltage safety	20.4 V to 264 V 50/60 Hz	195.5 V to 253 V 50/60 Hz
DC voltage safety	20.4 V to 264 V ---	—

4 Operating the devices

Automatic reset

The EMT6, EMT6-K and EMT6(230V) have a setting fixed to "Automatic reset" mode. The automatic reset can also be selected with the EMT6-DB, EMT6-DB(230V), EMT6-KDB and EMT6-DBK units. The selector switch (→ Fig. 7, Page 18, legend ③) is set to "AUTO" for this purpose.

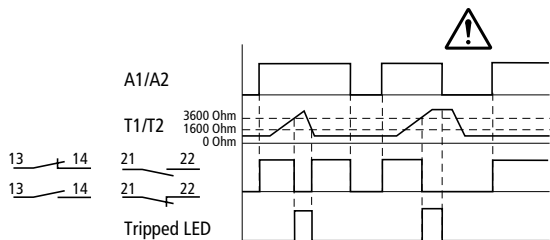

Figure 8 : Function diagram for automatic reset

After it has tripped, the device is reset when the equipment has cooled down.

The sensor circuits of the EMT6-K, EMT6-KDB and EMT6-DBK have additional short-circuit monitoring in the sensor circuit (→ Fig. 9, Page 22).



Warning!

To ensure explosion-proof operation, it is permitted only to reset/switch on the motor manually after the thermistor has cooled down, or to switch it on automatically via a control interlock circuit for the motor or electrical machinery.

A manual reset may be carried out on-site or from the control room by trained personnel.

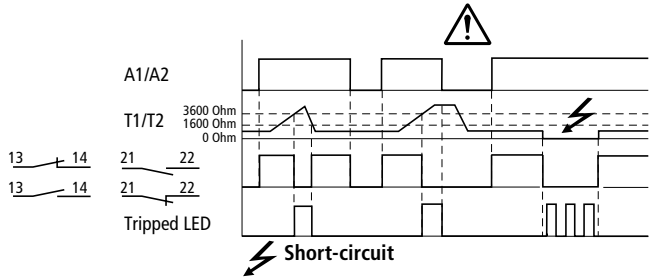

Figure 9 : Function diagram of automatic reset with short-circuit monitoring

Manual reset

The manual reset can also be selected with the EMT6-DB, EMT6-DB(230V), EMT6-KDB and EMT6-DBK units. The selector switch (→ Fig. 7, Page 18, legend ③) is set to “Manual” for this purpose.

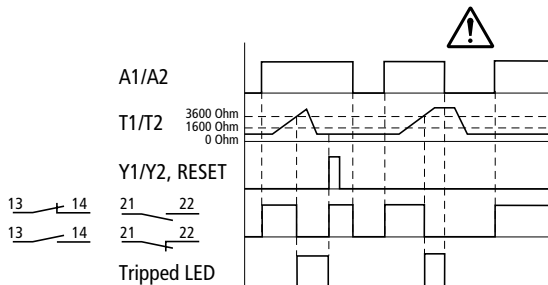

Figure 10 : Functional diagram of the manual reset (EMT6-DBK with disabled zero-voltage protection)

The sensor circuits of the EMT6-KDB and EMT6-DBK have additional short-circuit monitoring in the sensor circuit (→ Fig. 11, Page 23).

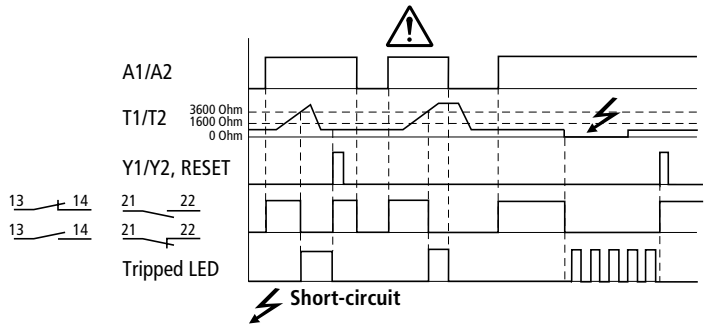

Figure 11 : Functional diagram of the manual reset with short-circuit monitoring (EMT6-DBK with disabled zero-voltage protection)



Warning!

After a power interrupt, the tripped relay switch back on automatically.



The circuit (→ Fig. 4, Page 16) prevents an automatic restart of the motor after voltage recovery.

Reclosing interlock and short-circuit protection

The EMT6-DBK features a reclosing interlock with zero-voltage protection and a short-circuit protection in the sensor circuit.

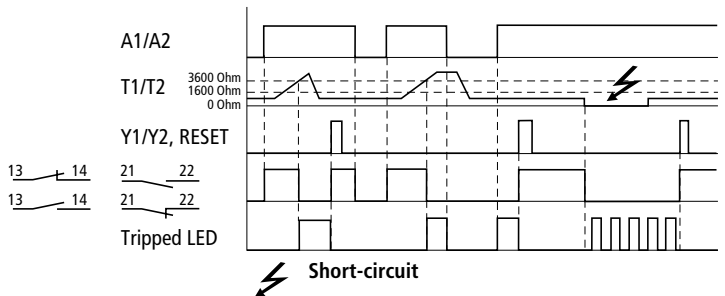

Figure 12 : Functional diagram of zero-voltage protected operation and short-circuit protection in the sensor circuit

➔ Zero-voltage protection can be disabled by bridging terminals Y1 and Y4 (➔ figure 7, Page 18).

➔ Short-circuit protection can be disabled by bridging terminals Y1 and Y3 (➔ figure 7, Page 18).

Test/Reset

The relay function can be tested by means of the test button.

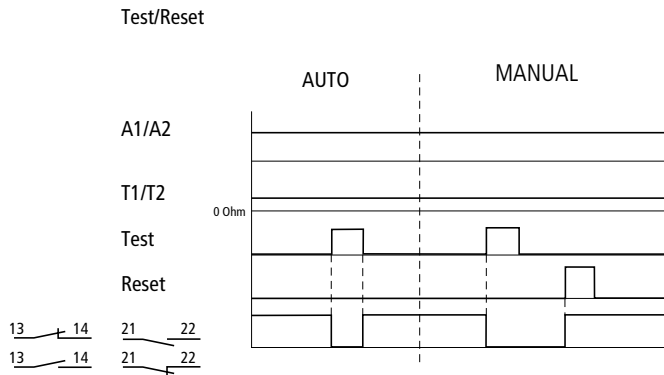

Figure 13 : Test/Reset functional diagram

Device fault



Warning!

Faulty devices may not be opened for repairs. They may only be replaced only by qualified personnel.

Annex

Rating plates

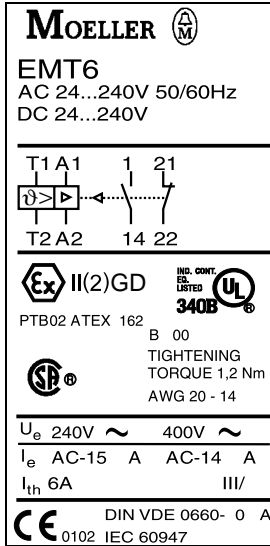

Figure 14 : EMT6

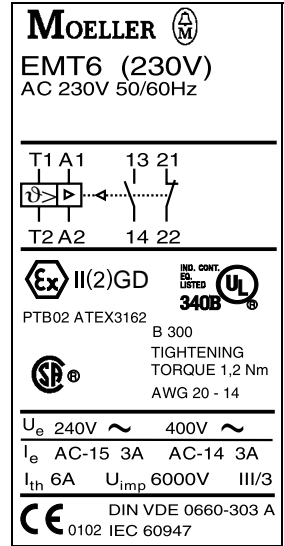

Figure 15 : EMT6(230V)

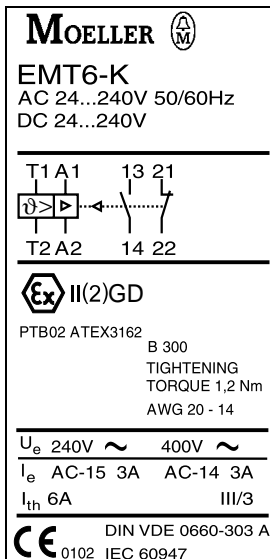

Figure 16 : EMT6-K

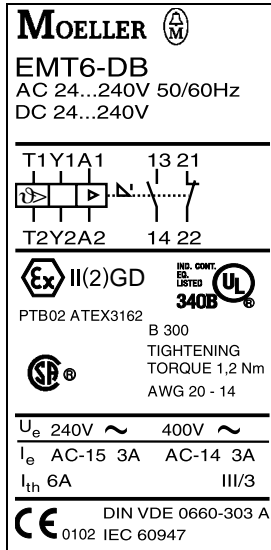

Figure 17 : EMT6-DB

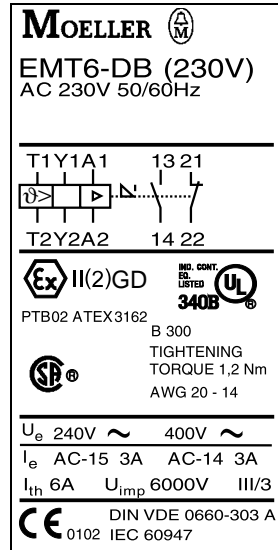

Figure 18 : EMT6-DB(230V)

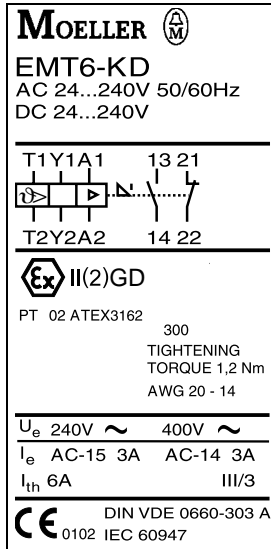

Figure 19 : EMT6-KDB

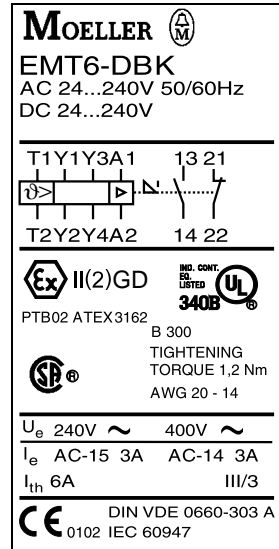

Figure 20 : EMT6-DBK

Dimensions

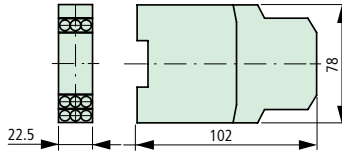

Figure 21 : Dimensions of the EMT6...

**Moeller GmbH
Industrieautomation
Hein-Moeller-Straße 7-11
D-53115 Bonn**

**E-Mail: info@moeller.net
Internet: www.moeller.net**

© 2002 by Moeller GmbH
Subject to alteration
AWB2327-1446GB IM-D/IM-D/xx 07/03
Printed in the Federal Republic of Germany (02/04)
Article No.: 267010



MOELLER 

Think future. Switch to green.

For Moeller Electric Sales and Support call KMparts.com (866) 595-9616