

Reliable and Precise Command and Signalling



xCommand

Command and signalling – ergonomic shape, attractive design. Switching control circuit currents reliably and precisely.

RMQ command and signalling devices

FAK foot and palm switches

SL indication pillars

Fingerprint M22-ESA

LS-Titan and AT position switches

T/P cam switches

ETR timing relays

EMR measuring relay

ESR safety relay

Selection aid

Position switches LS-Titan

Safety position switches AT

Proximity switches LSI, LSC, LSO

MOELLER 

Think future. Switch to green.

For Moeller Electric Sales and Support call KMparts.com (866) 595-9616

Movements safely under control Position switches, safety position switches and proximity switches

xCommand



From material handling systems to plastic injection moulding; from car washes to doors on trams: the position switches LS-Titan are used wherever there is exact positioning requirement.

With the new world innovation – the electronic position switch LS-E – even exact adjustment of the set position is no longer required. The operating point can be “learned”. Simply at the “touch of a button”.

The analog position switch with a voltage or current output also enables a range of new applications for the LS-Titan, where mechanical position detection could only provide insufficient information up to now – for example, detecting the position with opened flaps for flue gasses.

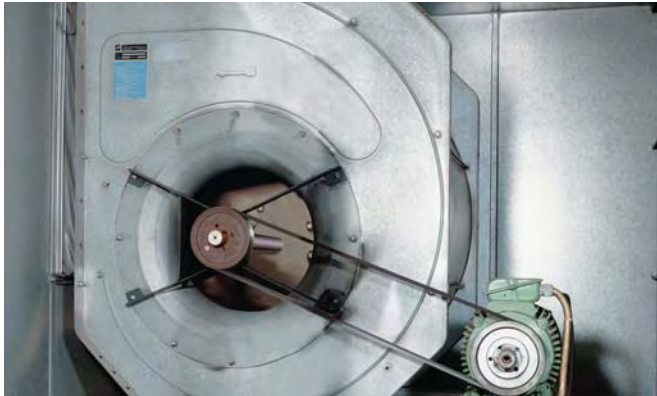

The new electronic position switches LSE-Titan are the ideal connection directly to the world of automation. This new innovation enables exact and continuous detection of the position of a flue gas flap or a servo drive. The position is converted to an analog voltage (0..10V) or current (4..20mA) and can be continuously signalled to the automation world. Even objects of differing thickness and size, such as brake blocks, can be detected and the signal can be processed. Simple, speed-dependent controls of ventilator motors or smoke removal systems indicate how wide the air ventilation flap is opened (e.g. 25, 50 or 75 percent) and thus save energy and protect and conserve the material.

For applications such as final inspections with packaging systems, non-intrusive detection is necessary in order to guarantee a smooth interruption-free process and extremely low levels of rejects. Capacitive proximity switches feature the ideal properties for this task. The advantage: they can detect both metallic and non-metallic objects non-intrusively and free of wear. Non-metals can be detected – even through other mediums. Thus, empty packages are detected, sorted out and can be refilled in order to guarantee a consistent high-level of quality. Further typical examples are for example, detection of wooden palettes, plastic containers or even liquids in glass containers.



Position switches LS-Titan

They are used wherever positions must be reliably detected. They are available either in robust metal or light plastic enclosure designs. Exchangeable operating heads enable flexible use for all applications. The highlight of the series, the LSE-Titan electronic position switch, connects mechanical position switches to the world of automation. Positions can be continually detected and monitored with these switches.



Safety position switches AT

Position switches for detection of safety-relevant facilities and equipment, e.g. doors, grilles or flaps. In addition to the standard safety switches, the range includes position switches with anti-tamper features for enhanced protection of personnel and processes, and only enable after a delay time. This ensures for example, that saws must come to a standstill or process stages must be completed before the machine, system or plant can be approached.



Proximity switches LSI, LSC, LSO

Modern automation engineering is practically unimaginable without the use of non-contact and non-invasive sensors. The speeds with which the processes are detected make the wear-free and robust sensors indispensable. Even under harsh conditions such as use in heavily contaminated environments. Inductive, capacitive or optical: the right proximity switch for every situation enables optimum, fast and safe use.

Electronic position switch LSE-Titan®

Setting a variable operating point



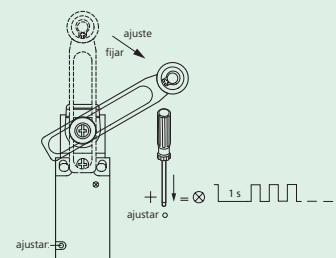
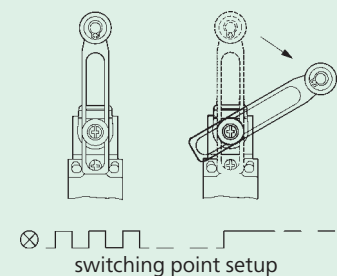
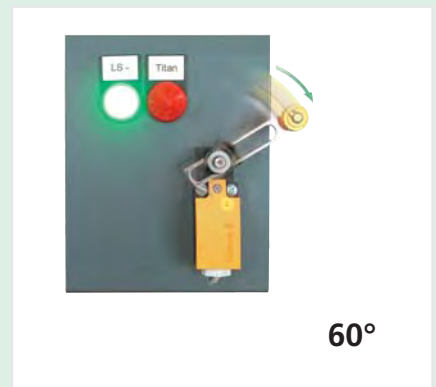
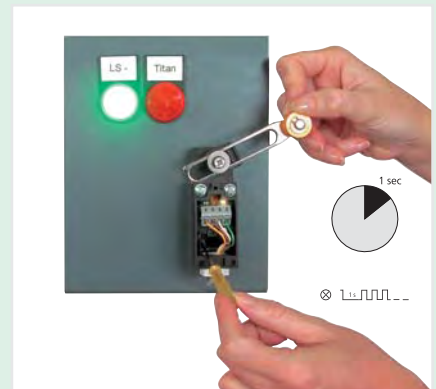
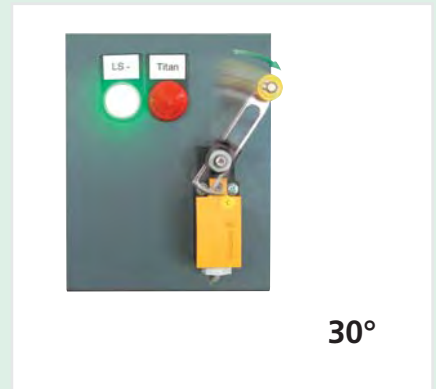

The electronic position switch LSE has an operating point that can be set variably. Two fast and bounce-free PNP switch outputs enable high switching frequencies. They are protected against short-circuit and overload and are equipped with an abrupt switching behaviour. This guarantees a defined and reproducible operating point. The actual operation point is in a range between 0.5 mm to 5.5 mm (supplied ex-works = 3 mm).

The setting to the "new" operating point is performed as follows: The plunger must be moved from the "old" to the "new" operating position. Now the set button should be pressed for a duration of 1 sec. The LED now flashes with a higher pulse frequency and the new operation point is set retentively.

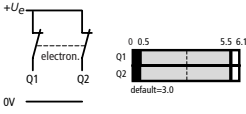
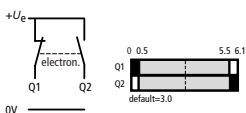

Limit switch electronic -LSE-

Individual adjustment of switching point

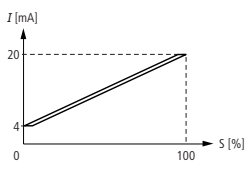
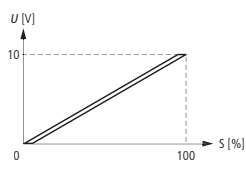
Position Switch LSE-Titan®		
Version	Contact sequence diagram for plunger	Part no.
Plastic version 		LSE-02
		LSE-11
Plastic version 		LSE-AI 4 – 20 mA
		LSE-AU 0 – 10 V



Simply snap on the command device RMQ-Titan®

A further unique feature is the ability to combine a control circuit device from the RMQ-Titan range with the LS-Titan position switches. Pushbutton actuators, selector switches or emergency-stop buttons can be simply snapped on directly as the operating heads on each position switch. The combined unit maintains the degree of protection IP66 on both the front and rear.

Analog electronic position switch LSE-Titan: Connecting analog, mechanically actuated position switches directly to the automation world.

The analog position switches LSE-AI (4-20mA) and LSE-AU (0-10V) are a further electronic position switch innovation. It is possible for the first time, to continuously monitor the actual position of a flue gas flap or an actuator. Hereby, the position is detected on an analog basis with voltage (0-10V) or current (4-20mA) and continuously signaled to the automation world. Even objects with differing thicknesses, such as brake blocks can be detected and the signal can be processed.

Simple speed-dependent controls for fan motors or smoke extraction fans signal the opening width of the air flap (e.g. 25, 50 or 75 percent) and thus save energy and material. The analog position switch also features a diagnostics output for further signal processing. It enables monitoring and evaluation of the safe state at any time. The position switch also features a self-test function: Outputs Q1 and Q2 are continuously tested for overload, short-circuit to 0V and short-circuit to $+U_e$.



Simple to mount

The operating heads can be attached in all 4 directions (4 x 90°) and can be quickly and safely snap mounted using the bayonet fitting. Modern, reliable and fast mounting is assured in conjunction with the vibration-proof and maintenance-free cage-clamp terminals.

Position Switch LS-Titan®



NEMA 4X, 13 IP 66		Contact sequence diagram for plunger	Plunger DIN EN 50 047	Plunger DIN EN 50 047	Roller Plunger DIN EN 50 047	Contact sequence diagram for front fixing	Front fixing DIN EN 50 047	Contact sequence diagram for spring rod	Spring- Rod
Version	Contacts		Part no.	Part no.	Part no.		Part no.		Part no.
plastic version	- 2N/C ⊕		LS-02	LS-02-SW			LS-02/F		
	1N/O 1N/C ⊕		LS-11	LS-11-SW	LS-11/P		LS-11/F		
	1N/O 1N/C ⊕		LS-11D	LS-11D-SW			LS-11D/F		
	1N/O 1N/C ⊕		LS-11S²	LS-11S-SW²	LS-11S/P²		LS-11S/F²		LS-11S/S²
	2N/O -		LS-20	LS-20-SW			LS-20/F		
	1N/O 1N/C ⊕		LS-11DA				LS-11DA/F		
	2N/O -		LS-20A				LS-20A/F		
metal version	- 2N/C ⊕		LSM-02				LSM-02/F		
	1N/O 1N/C ⊕		LSM-11		LSM-11/P		LSM-11/F		
	1N/O 1N/C ⊕		LSM-11D				LSM-11D/F		
	1N/O 1N/C ⊕		LSM-11S²		LSM-11S/P²		LSM-11S/F²		LSM-11S/S²
	2N/O -		LSM-20				LSM-20/F		
	1N/O 1N/C ⊕		LSM-11DA				LSM-11DA/F		
	2N/O -		LSM-20A				LSM-20A/F		

⊕ = positive opening safety function to IEC/EN 60947-5-1

² LS/LSM-..S = Snap-Action contact



Contact sequence diagram for roller lever short	Roller lever short	Contact sequence diagram for roller lever long	Roller lever long DIN EN 50 047	Contact sequence diagram for roller lever large	Roller lever large	Contact sequence diagram for rotary lever, adjustable roller lever and actuating rod	Rotary lever DIN EN 50 047	Adjustable roller lever	Actuating rod
	Part no.		Part no.		Part no.		Part no.		
			LS-02/L						
	LS-11/LS		LS-11/L		LS-11/LB		LS-11/RL	LS-11/RLA	
	LS-11D/LS		LS-11D/L						
			LS-11S/L²				LS-11S/RL²	LS-11S/RLA²	LS-11S/RR²
			LSM-02/L						
			LSM-11/L				LSM-11/RL	LSM-11/RLA	
			LSM-11D/L						
			LSM-11S/L²				LSM-11S/RL²	LSM-11S/RLA²	LSM-11S/RR²

LS-Titan® operating heads, accessories

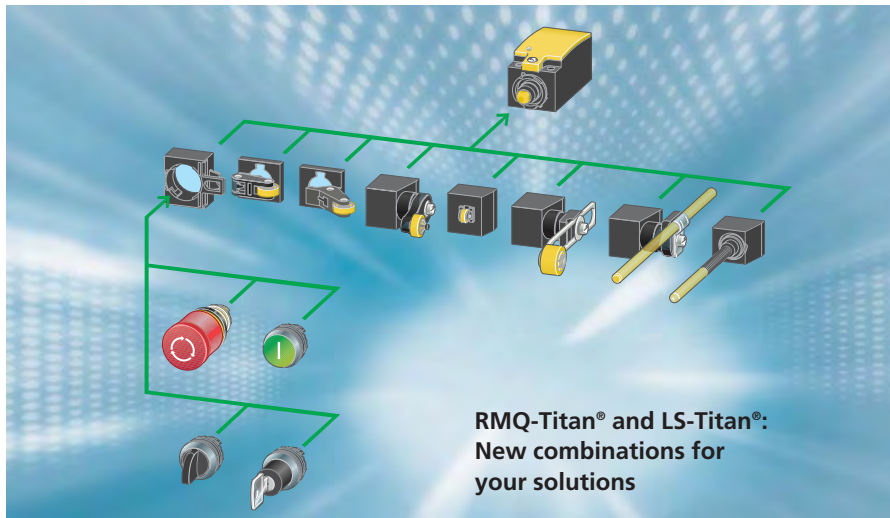

	Roller lever short	Roller lever long	Roller lever large	Angled roller lever	Roller plunger	Rotary lever	Adjustable roller lever d=18mm	
Version	Part no.	Part no.	Part no.	Part no.	Part no.	Part no.	Part no.	
Plastic version	LS-XLS 	LS-XL 	LS-XLB 	LS-XLA 	LS-XP 	LS-XRL 	LS-XRLA 	
Metal version		LSM-XL 		LSM-XLA 	LSM-XP 	LSM-XRL 	LSM-XRLA 	

LS-Titan® Position Switch			plastic version		metal version
	NEMA 4X, 13 IP 66	Contact sequence diagram for plunger	Plunger DIN EN 50 047	Plunger, Black DIN EN 50 047	Plunger DIN EN 50 047
			Part no.	Part no.	Part no.
	- 2N/C ⊕		LS-02	LS-02-SW	LSM-02
	1N/O 1N/C ⊕		LS-11	LS-11-SW	LSM-11
	1N/O 1N/C ⊕		LS-11D	LS-11D-SW	LSM-11D
	1N/O 1N/C ⊕		LS-11S ²	LS-11S-SW ²	LSM-11S ²
	2N/O -		LS-20	LS-20-SW	LSM-20
	1N/O 1N/C ⊕		LS-11DA		LSM-11DA
2N/O -		LS-20A		LSM-20A	

⊕ = positive opening safety function to IEC/EN 60947-5-1

² LS/LSM-..S = Snap-Action contact

Adjustable roller lever d=30mm	Adjustable roller lever d=40mm	Adjustable roller lever d=40mm (Rubber)	Plastic actuating rod	Metal actuating rod	Spring rod actuator	Actuating rod	RMQ-Titan fixing adapter	Cage-Clamp connector
Part no.	Part no.	Part no.	Part no.	Part no.	Part no.	Part no.	Part no.	Part no.
LS-XRLA30	LS-XRLA40	LS-XRLA40R	LS-XRR	LS-XRRM	LS-XS	LS-XOR	M22-LS	LS-XTW
			LSM-XRR	LSM-XRRM	LSM-XS			

Door safety switch ATR

Position safety switch AT 0

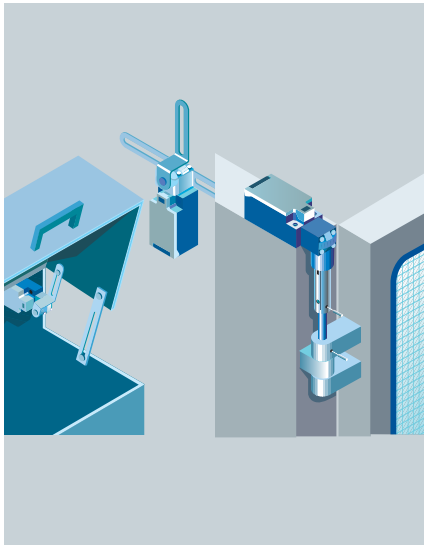

Safety for persons and processes door safety switch ATR-... /T(K,S)

The safety of all personnel working in production halls must be ensured at all times. Protective doors and hinged flaps keep people out of hazardous areas. Where an attempt is made to open a protected door or flap during operation, the hinge-operated switches ATR/TS and the hasp-operated switches ATR/TK immediately disconnect the power supply to the machine or installation. Opening is registered at an angle of only 5 degrees, and so even tampering is not possible.

Wherever tampering must be absolutely prevented and protruding actuating levers would be unacceptable, door switches offer protection on tooling and packaging machines or in areas where robots operate.

If the hasp-operated switches ATR/TK are fitted inside a cover, tampering is completely eliminated.

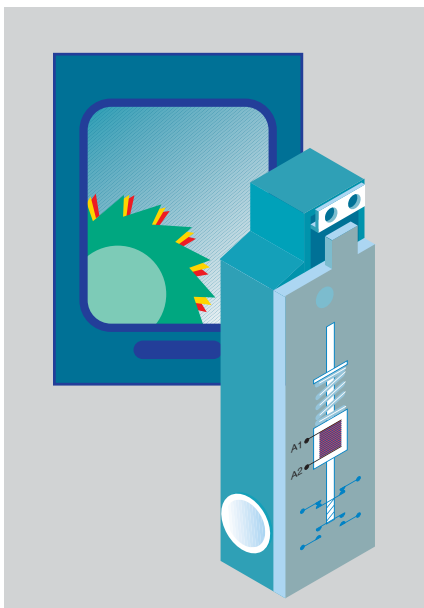

Protect and lock: safety position switch AT 0-...-ZBZ

By reliable securing and interlocking of protective doors, the AT 0-ZBZ increases the safety standards for the protection of personnel and processes.

The AT 0-ZBZ operates according to one of two principles: on the basis of magnet-powered or spring-powered interlocking.

The spring-powered interlock is optimally suited for enhanced personnel protection. The door or protective guard remains safely locked even in the event of power failure. In an emergency, the protective guard can be opened using an auxiliary release mechanism. Magnet-powered interlock is used in personnel and process protection. The protective cover is interlocked when operational voltage is applied, and can therefore be opened directly in the event of power failure.

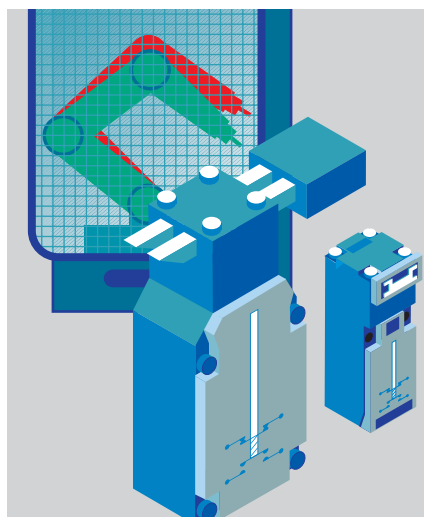

Switch off the danger: safety position switches AT...ZB

Safety position switches AT 0-ZB and AT 4-ZB are used on centrifuges, motor and gearbox covers, presses, etc.. If the protective guard is opened, they disconnect the power and in so doing, remove the danger. AT 0-ZB and AT 4-ZB comply with EN 1088 "Interlocks with and without mechanical securing action". The selection of the necessary protective device is thus simplified. All safety position switches also fulfil the demands for use in safety circuits by their use of positively driven switching elements and positively opening contacts.

Equipped with double-break contacts, they are also suitable for use in the configuration of redundant safety circuits. The switches featuring double break contacts are suitable for use with electronic devices in accordance with IEC/EN 61 131-2, enabling the safe exchange of information with any controller.



Door safety switch, IP65

Complete units Contacts ■ closed □ open Zw = Positive opening sequence	Door flap safety switch ATR-.../TK narrow	Complete units Contacts ■ closed □ open Zw = Positive opening sequence	Door hinge safety switch ATR-.../TS narrow
Switching diagram	Part no.	Switching diagram	Part no.
	ATR-11-1-I/TKG		ATR-11-1-I/TS
	ATR-02-1-I/TKG		ATR-02-1-I/TS

AT 0...-ZBZ safety position switches, IP65

Basic unit	Spring-powered interlock (closed-circuit principle)	Magnet-powered interlock (open, circuit principle)
Rated control voltage U _s magnetic drive	Part no.	Part no.
24 V DC	AT0-11-24 DFT-ZBZ/X	AT0-11-24 DMT-ZBZ/X
24 V DC	AT0-02-24 DFT-ZBZ/X	AT0-02-24 DMT-ZBZ/X
120 V DC 50/60 Hz	AT0-11-120 AFT-ZBZ/X	AT0-11-120 AMT-ZBZ/X
120 V DC 50/60 Hz	AT0-02-120 AFT-ZBZ/X	AT0-02-120 AMT-ZBZ/X
230 V DC 50/60 Hz	AT0-11-230 AFT-ZBZ/X	AT0-11-230 AMT-ZBZ/X
230 V DC 50/60 Hz	AT0-02-230 AFT-ZBZ/X	AT0-02-230 AMT-ZBZ/X

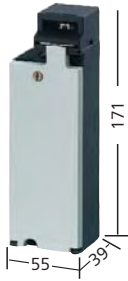

AT...-ZB safety position switches, IP65

Complete unit	Narrow Part no.
	AT0-11-1-ZB
	AT0-02-1-ZB
	AT4/11-1/I/ZB

Actuators for combination with AT 0...-ZBZ basic units

Version	Mechanical holding force	Part no.
Straight for sliding doors	2,000 N	G-ZBZ
Angled for swing doors	2,000 N	W-ZBZ
Flexible, angled for doors that do not close precisely	1,000 N	F-ZBZ
Flexible, straight for doors that do not close precisely	1,800 N	FG-ZBZ
Straight, with increased tolerance in closing direction for doors that does not close precisely	1,800 N	NG-ZBZ
Angled, with increased tolerance in closing direction for doors that does not close precisely	1,000 N	NW-ZBZ

Proximity switches – safe switching without contact



Inductive proximity switches

Inductive proximity switches are the robust standard product to safely detect the presence of metallic objects. The non-contact detection with electronic output ensures almost an unrestricted lifespan as there is no wear, even under extremely contaminated conditions.

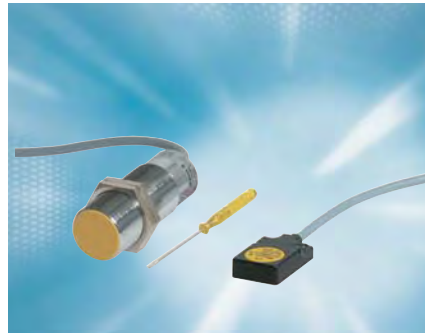

Capacitive proximity switches

Capacitive proximity switches are used wherever non-metallic objects have to be detected. It is possible for example to control fill levels, or prevent that containers run dry or overflow. Substances can even be detected through glass, plastic, etc.

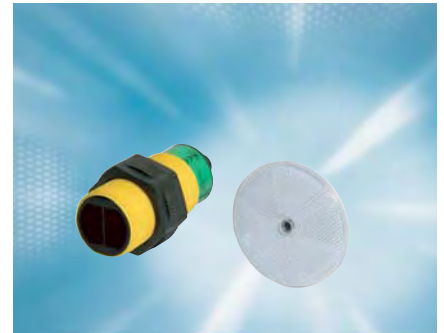

Optical proximity switches

The reflected-light beam switch contains a transmitter and receiver and can detect objects which are within an operating range of up to 300 mm. The reflected-light barrier operates with reflectors of different sizes. In order to detect objects with glossy surfaces, the series also includes types with polarising filters. Thus, ranges of up to 6000 mm can be covered.

Optical proximity switches LSO

Optical proximity switches LSO			
	Housing style (Round design)	DC voltage version – switching to + pole (PNP) U_e : 10..30V DC I_e max 150 mA	
		With 2 m connecting cable	With plug-in connection
	Reflected-light beam without background suppression M 18 x 1		
	Plastic	LSO-R18P-S300-LD Sd 300mm, P	LSO-R18P-S300-PD Sd 300mm, P
	Metal	LSO-R18S-S300-LD Sd 300mm, P	LSO-R18S-S300-PD Sd 300mm, P
	Reflected-light beam with fixed background suppression M 30 x 1.5		
	Plastic	LSO-R30P-S400-LD Sd 400mm, P	LSO-R30P-S400-PD Sd 400mm, P
	Reflected-light barrier without polarisation filter M 18 x 1		
	Plastic	LSO-R18P-B2000-LD Sd 2000mm, P	LSO-R18P-B2000-PD Sd 2000mm, P
	Metal	LSO-R18S-B2000-LD Sd 2000mm, P	LSO-R18S-B2000-PD Sd 2000mm, P
	Reflected-light barrier with polarisation filter M 30 x 1.5		
	Plastic	LSO-R30P-B6000-LD Sd 6000mm, P	LSO-R30P-B6000-PD Sd 6000mm, P
	Light-barrier reflectors for reflected-light barrier		
		40mm 75mm	LSO-XR40 LSO-XR75

Sd: operating range P = programmable (break contact or make contact)

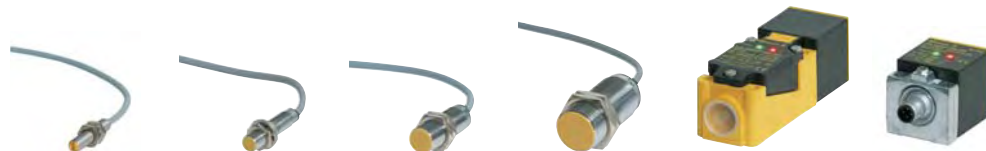

Inductive proximity switches LSI						
Enclosure style	Round design				Rectangular design	
	DC voltage version – switching to + pole (PNP)					
	U_e : 10..30V DC				U_e : 10..65V DC	U_e : 10..30V DC
	Part no. M 8x1	Part no. M 12x1	Part no. M 18x1	Part no. M 30x1.5	Part no. 114x40x40	Part no. 65x40x40
Plastic housing*, Fitting in metal: Flush		LSI-R12P-F2-LD Sn 2mm, N/O	LSI-R18P-F5-LD Sn 5mm, N/O	LSI-R30P-F10-LD Sn 10mm, N/O	LSI-Q40P-F20-CD Sn 20mm, C/O	
Plastic housing*, Fitting in metal: Non-flush		LSI-R12P-NF4-LD Sn 4mm, N/O	LSI-R18P-NF8-LD Sn 8mm, N/O	LSI-R30P-NF15-LD Sn 15mm, N/O	LSI-Q40P-NF40-CD Sn 40mm, C/O	
Plastic insulated housing with plug-in connection, Fitting in metal: Flush						LSI-Q40P-F20-PD Sn 20mm, N/O
Plastic insulated housing with plug-in connection, Fitting in metal: Non-flush						LSI-Q40P-NF35-CD Sn 35mm, N/O
Metal housing with 2 m connection cable, Flush	LSI-R85-F1-LD Sn 1.5mm, N/O	LSI-R12M-F2-LD Sn 2mm, N/O	LSI-R18M-F5-LD Sn 5mm, N/O	LSI-R30M-F10-LD Sn 10mm, N/O		
Metal housing with plug-in connection, Flush	LSI-R85-F1-PD Sn 1.5mm, N/O	LSI-R12M-F2-PD Sn 2mm, N/O	LSI-R18M-F5-PD Sn 5mm, N/O	LSI-R30M-F10-PD Sn 10mm, N/O		
Metal housing with plug-in connection, Non-flush	LSI-R85-NF3-PD Sn 3mm, N/O	LSI-R12M-NF4-PD Sn 4mm, N/O	LSI-R18M-NF8-PD Sn 8mm, N/O	LSI-R30M-NF15-PD Sn 15mm, N/O		
Alternating voltage version 20-250 V AC, 50/60 Hz						
Plastic housing*, Fitting in metal: Flush		LSI-R12P-F2-LA Sn 2mm, N/O	LSI-R18P-F5-LA Sn 5mm, N/O	LSI-R30P-F10-LA Sn 10mm, N/O	LSI-Q40P-F20-CA Sn 20mm, P	
Plastic housing*, Fitting in metal: Non-flush					LSI-Q40P-NF35-CA Sn 35mm, P	

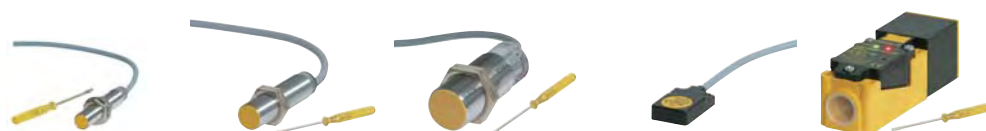

Capacitive proximity switches LSC					
Housing style	Round design			Rectangular design	
	DC voltage version – switching to + pole (PNP)				
	U_e : 10..30V DC	U_e : 10..65V DC		U_e : 10..30V DC	U_e : 10..65V DC
	Part no. M 12x1	Part no. M 18x1	Part no. M 30x1.5	Part no. 32x20x8	Part no. 114x40x40
Plastic insulated housing with 2 m connection cable, fitting in metal: Flush	LSC-R12M-F3-LD Sn 3mm, N/O	LSC-R18M-F5-LD Sn 5mm, N/O	LSC-R30M-F10-LD Sn 10mm, C/O	LSC-Q20M-F5-LD Sn 5mm, N/O	
Plastic insulated housing with terminal connection, fitting in metal: Flush					LSI-Q40P-F20-CD Sn 20mm, C/O

* on round style: 2 m connecting cable,
on rectangular style: with terminal connection

Sn: rated switching distance

M12 x 1 plug connector

N/O = normally open

C/O = changeover

P = programmable (break contact or make contact)

Dimensions Position Switches LS-Titan®

Position switches
LS-..., LSM-..., LSE-..

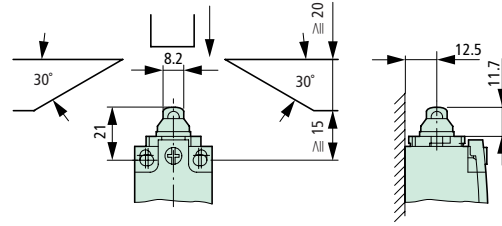
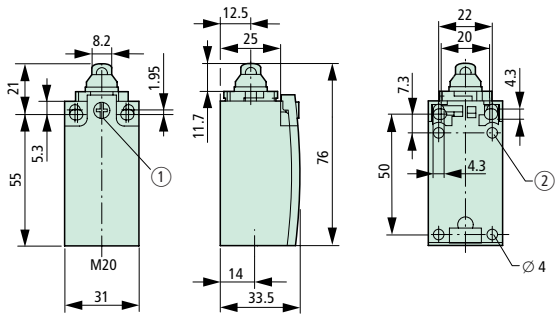

① Tightening torque of cover screw: 1.0 Nm ± 0.2 Nm ② Only with LS (plastic design)

LS-11 (S)/P

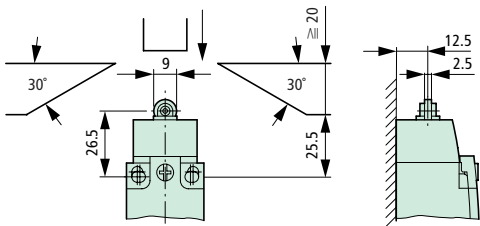

LS(M)-11(S)/RL

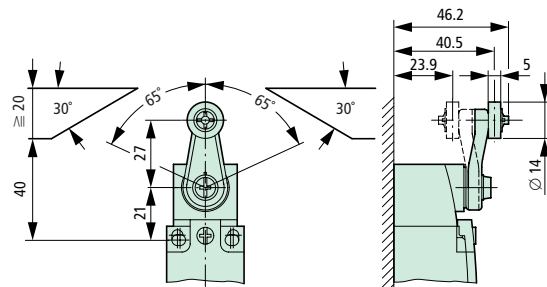

LS(M)-11(S)/RLA

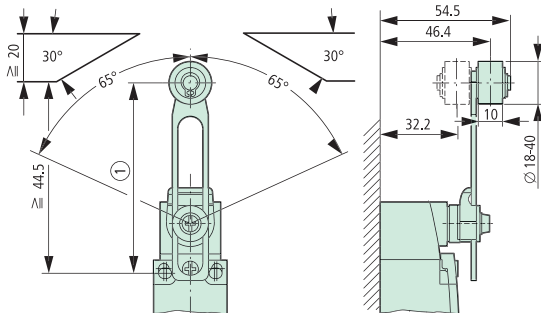

LS(M)-11S/S

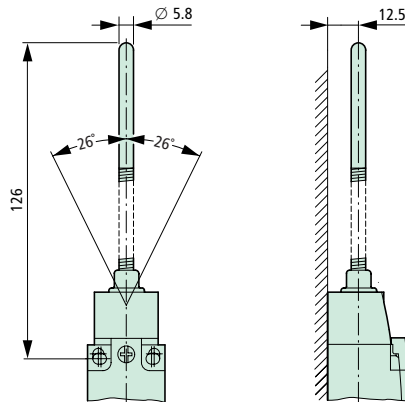

① Setting range from 54.5 to 97

LS(M)-.../L

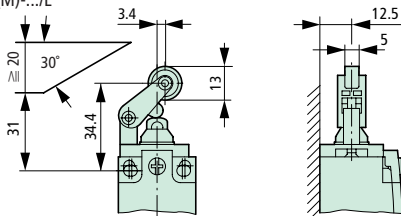

LS(M)-11S/RR

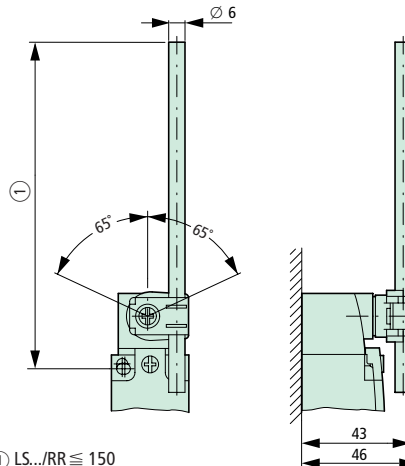

① LS.../RR ≅ 150
LS.../RRR ≅ 210

LS(M)-XL(A)

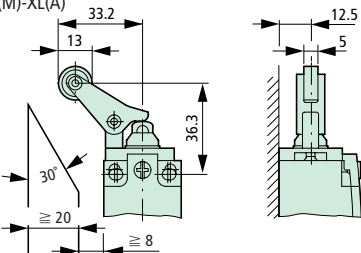

Technical Data

Complete unit to IP66

LS, LSM

LSE-11, LSE-02

LSE-AI

LSE-AU

General

Standards and regulations		IEC/EN 60947	IEC/EN 60947, EN 61000-4	IEC/EN 60947, EN 61000-4	IEC/EN 60947, EN 61000-4
Climatic proofing		Damp heat, constant to IEC 60068-2-3, Damp heat, cyclic to IEC 60068-2-30			
Ambient temperature	°C	-25/+70	-25/+70	-25/+70	-25/+70
Mounting position		as required	as required	as required	as required
Degree of protection		IP66	IP66	IP66	IP66
Cage Clamp terminal capacity					
solid	mm ²	1 x (0.5 – 2.5)	1 x (0.5 – 2.5)	1 x (0.5 – 2.5)	1 x (0.5 – 2.5)
flexible with ferrule	mm ²	1 x (0.5 – 1.5)	1 x (0.5 – 1.5)	1 x (0.5 – 1.5)	1 x (0.5 – 1.5)
DIN 46228					

Power Supply

Rated voltage	U_e	V DC	–	12 – 30	24 (–15%/+20%)	24 (–15%/+20%)
Rated operational current						
12 V	I	mA	–	15	–	–
24 V	I	mA	–	18	28 – 45	24
30 V	I	mA	–	19	–	–

Conductors/Switching capacity

Rated impulse withstand voltage	U_{imp}	V AC	4000	–	–	–
Rated isolation	U_i	V	400	–	–	–
Overvoltage category/ pollution degree			III/3	III/3	III/3	III/3
Rated operational current						
AC-15 24 V	I_e	A	6	–	–	–
230 V/240 V	I_e	A	6	–	–	–
400 V/415 V	I_e	A	4	–	–	–
DC-13 24 V	I_e	A	3	0.2	–	–
110 V	I_e	A	0.8	–	–	–
220 V	I_e	A	0.3	–	–	–

Analog output Q1

Output voltage (max. 10 mA)		V DC	–	–	–	0 – 10
Output current		mA	–	–	4 – 20	–
Fault scenario		V	–	–	0	0
Resolution		Steps	–	–	100	100
Step tolerance		Step	–	–	< 2	< 2
Load impedance, resistive load		Ω	–	–	< 400	> 1000

Digital diagnostic output Q2 (switching to +pole PNP)

Normal operation		V	–	–	approx. U_e	approx. U_e
		m A	–	–	< 200	< 200
Fault scenario		V	–	–	0	0

Control circuit reliability

at 24 V DC/5 mA	H_F	Fault-frequency	< 10 ⁻⁷ , < 1 fault in 10 ⁷ operations	–	–	–
at 5 V DC/1 mA	H_F	Fault-frequency	< 10 ⁻⁶ , < 1 fault in 5 x 10 ⁶ operations	–	–	–

Mains frequency

		Hz	max. 400	–	–	–
--	--	----	----------	---	---	---

Short-circuit rating in closed state (IEC/EN 60947-5-1)

Fuseless	Type	PKZM 0-10 PXL-B6/1	non-inherently short-circuit proof, after reset switch back on	non-inherently short-circuit proof, after reset switch back on	non-inherently short-circuit proof, after reset switch back on
Max. fuse	A gG/gI	10	–	–	–

Short-circuit rating to IEC/EN 60947-5-1

Max. fuse	A gG/gI	6	–	–	–
-----------	---------	---	---	---	---

Repetition accuracy

	mm	± 0.02	± 0.02	± 0.02	± 0.02
--	----	--------	--------	--------	--------

Note

The following applies for LSE-11, LSE-02: Ensure that the voltage supply is not interrupted when setting the switching point.
Cage-Clamp is a registered trademark of Wago Kontakttechnik, 32423 Minden, Germany.
Accessories and actuation tools for the Cage-Clamp connection available from Wago:
Actuation tool, 2-way, Wago article no. 280-432
Screwdriver short, angled, Wago article no. 210-258
Jumper insert, grey, Wago article no. 264-402